



Scanning Laser Range Finder

UXM-30LX-EW for Outdoor applications

- Ethernet Interface
- Multi-Echo Detection for Outdoor Applications
- IP67

Detectable in Snowy, Rainy, Foggy and Dusty conditions.



Provisional Specification

Products	Laser Range Finder
Model number	UXM-30LX-EW
Supply voltage	10 to 30VDC
Consumption current	During operation : 500mA or less at 10/12VDC, 250mA or less at 24VDC Start-up : 2A or less at 10VDC, 1.5A or less at 12VDC, 0.75A or less at 24VDC
Light source	Laser diode $\lambda=905\text{nm}$, Laser class 1
Principle	Direct Time of Flight
Detection range	0.1 to 30m *1 Black(diffuse reflectance 10%, 500mm X 500mm), 190°
Multi-Echo function	Max. 3-output of distance data per step
Accuracy	Under 3,000lux or less : 0.1 to 10m $\pm 50\text{mm}^{*2}$ (Black: diffuse reflectance 10%, 500mm X 500mm) Under 100,000lux or less : 0.1 to 30m $\pm 100\text{mm}^{*2}$ (Black: diffuse reflectance 10%, 500mm X 500mm)*2
Angular Resolution	0.25°
Scanning Speed	50msec/scan (Motor speed : 1200rpm)
Interface	Ethernet 100BASE-TX (Auto-negotiation), TCP/IP Synchronous output , Trouble output (Nch Open drain output 30VDC 100mA or less)
Indication lamp	Power(Green), Operating/Trouble (Orange) Operating : light-up Trouble : blink
Communication protocol	SCIP2.2 (Exclusive command)
Connection	Power source / output (cable 2m length), Ethernet (Connector model 09-0431-87-04 Binder products *3)
Ambient temperature and humidity	10 to +50°C (-25 to +75°C when stored), 85%RH or less (without condensing and icing)
Vibration resistance	Double amplitude 1.5mm, 10 to 55Hz for each 2 hours in X, Y and Z directions
Impact resistance	196m/s ² , each 10 times in X, Y and Z directions
Protective structure	IP67 (IEC standard)
Weight	Approx. 800g (not including the cable weight)

*1 Please verify the actual performance of the sensor under the intended working environment conditions.

*2 Measurement under direct interference light is not assured (Sunlight, etc.).

*3 The other side : Binder products 99-0430-57-04 (Option).

Note) This model is not a safety rated product.

Note) Hokuyo products are not developed and manufactured for use in weapons, equipment, or related technologies intended for destroying human lives or creating mass destruction. If such possibilities or usages are revealed, the sales of Hokuyo products to those customers might be halted by the laws of Japan such as Foreign Exchange Law, Foreign Trade Law or Export Trade Control Order. In addition, we will export Hokuyo products for the purpose of maintaining the global peace and security in accordance with the above laws of Japan .

External Dimensions

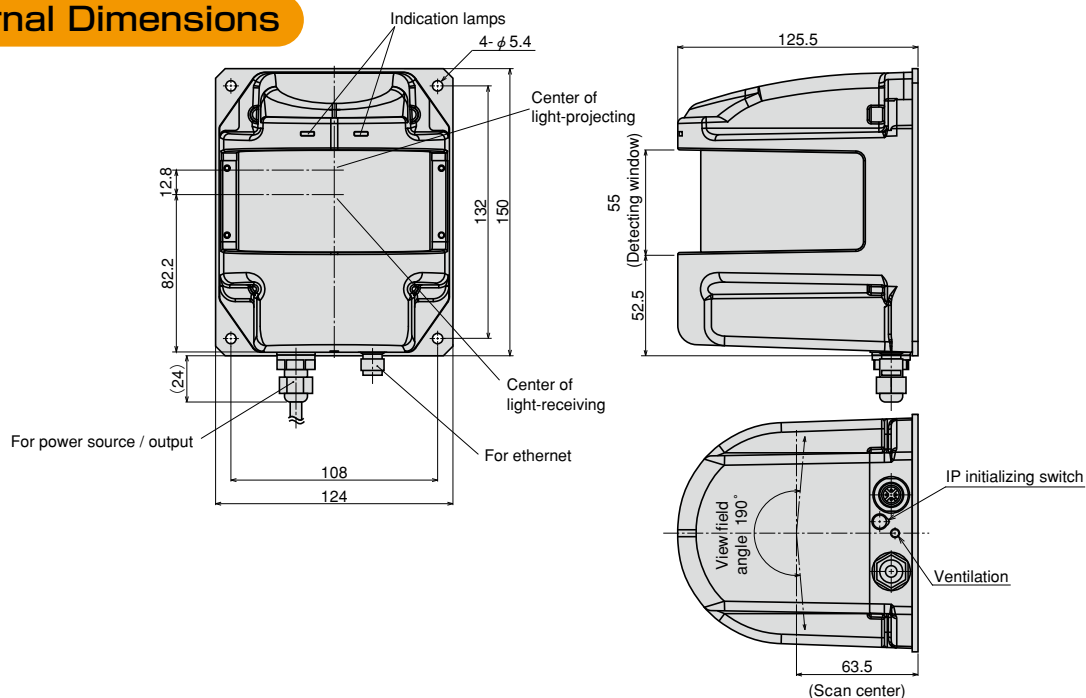

★All information in this catalog is subject to change without notice.

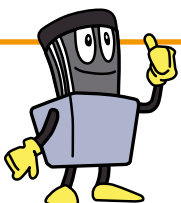

International Sales Agencies :

India, Korea, Malaysia, Sweden, Taiwan,
Thailand, UK, USA



HOKUYO AUTOMATIC CO.,LTD.

Osaka HU Building, 2-2-5 Tokiwamachi, Chuo-Ku, Osaka, 540-0028 Japan
TEL:+81-6-6947-6333 FAX:+81-6-6947-6350
URL :<http://www.hokuyo-aut.jp>
Email : info@hokuyo-aut.jp