

Description

- Operation mode and max sensing range:
Thru-beam: 0-70 m
Diffuse proximity: 0-5 m
- 230 V ac, 115 V ac, 24 V ac or 24 V dc supply voltage
- Manual sensitivity adjustment
- Sensor LED-drive
- Automatic sensor test
- Adjustable on/off time delay
- 1 relay and 1 transistor output or 2 transistor outputs
- Switch selectable light or dark function
- Switch selectable long or short range
- Power, output and signal level indicators
- 11-pole DIN socket connection



The PA 11 is a 1-channel photoelectric amplifier, which is to be used in conjunction with a set of remote transmitter LT and receiver LR from the series 100, 110 and 120.

This amplifier series offers manual sensitivity adjustment via integral potentiometers located on the front panel of the amplifier. Output can be selected from either a relay and NPN or NPN and PNP transistor outputs with or without a 0-10 sec on/off time delay. Light or dark function and long or short range are switch selectable.

The microprocessor controlled sensor test ensures that the system will automatically detect and indicate a faulty transmitter or receiver – cable break or electrical failure – during operation, through the relevant LED located on the front panel. The sensor LED drive powers the optional monitor LEDs available on the remote sensors – output (LT) and power (LR).

Technical Data		
Supply voltage		24 V dc, 24 V ac, 115 V ac or 230 V ac
Voltage tolerance		+/- 15 %
Current consumption		Max. 3,5 VA
Output	Relay	1 open / 1 close, 250 V ac / 3 A, 120 V ac / 5 A
	Transistor	
		60 mA / 30 V dc
Power on indicator		Green LED
Output indicator		Yellow LED
Signal level indicator		Green LED
LR sensor failure indicator		Red LED
LT sensor failure indicator		Red LED
Sensor monitor LED drive		The green monitor LED on the receiver indicates 'Power ON' The yellow monitor LED on the transmitter indicates 'PA 11 output activated'
Hysteresis		Approx. 45 %
Operation frequency	Relay	14 Hz
	Transistor	20 Hz
Response time t_{ON} / t_{OFF}	Relay	35 ms / 35 ms
	Transistor	25 ms / 25 ms
Delay t_{ON} / t_{OFF}	PA 11 A	0 – 10 sec, adjustable
Housing material		Noryl

Environmental Data		
Temperature, operation		-10 to +50 °C
Temperature, storage		-40 to +80 °C
Sealing class		IP 40
Approvals		CE

Available Types

Model	Connection	Supply Voltage	24 V dc	24 V ac	115 V ac	230 V ac
		Output	Order Reference			
PA 11 A On/Off delay	11-pole DIN socket	Relay and NPN	PA 11 A 303T	PA 11 A 302T	PA 11 A 301T	PA 11 A 300T
		NPN and PNP	PA 11 A 403T	PA 11 A 402T	PA 11 A 401T	PA 11 A 400T
PA 11 B		Relay and NPN	PA 11 B 303T	PA 11 B 302T	PA 11 B 301T	PA 11 B 300T
		NPN and PNP	PA 11 B 403T	PA 11 B 402T	PA 11 B 401T	PA 11 B 400T

Note: Remote sensors and 11-pole DIN socket to be ordered separately.

Applicable Remote Sensors and Ranges

Series	Thru-beam	Diffuse Proximity
100	18 m	1,1 m
110	40 m	2 m
120	70 m	5 m

Wiring Diagrams

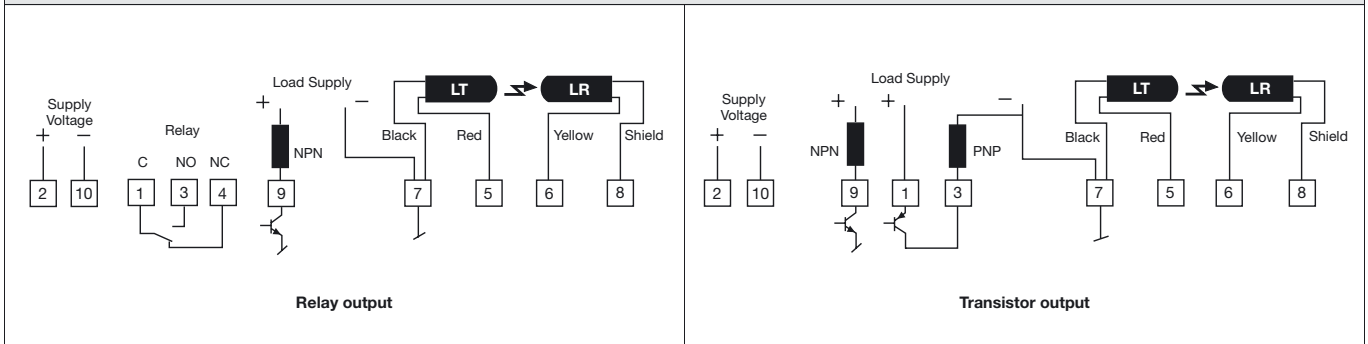

Dimensions and Descriptions

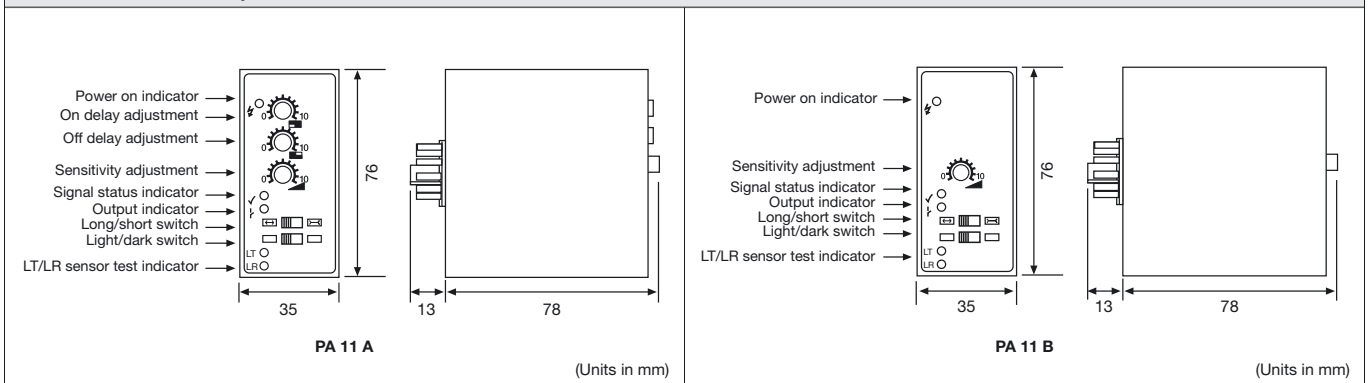

Telco reserves the right to change specifications without notice.